

Zylinderwagen-
Motor

Moteur du chariot
de cylindre

Cylinder carriage
motor

Farbwerk-
Motor

Moteur du système
d'encrage

Ink unit motor

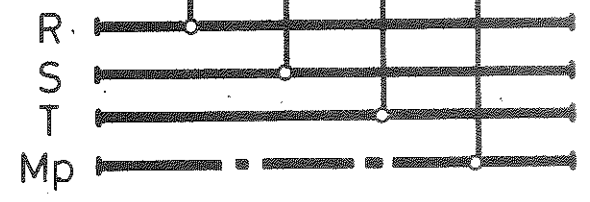
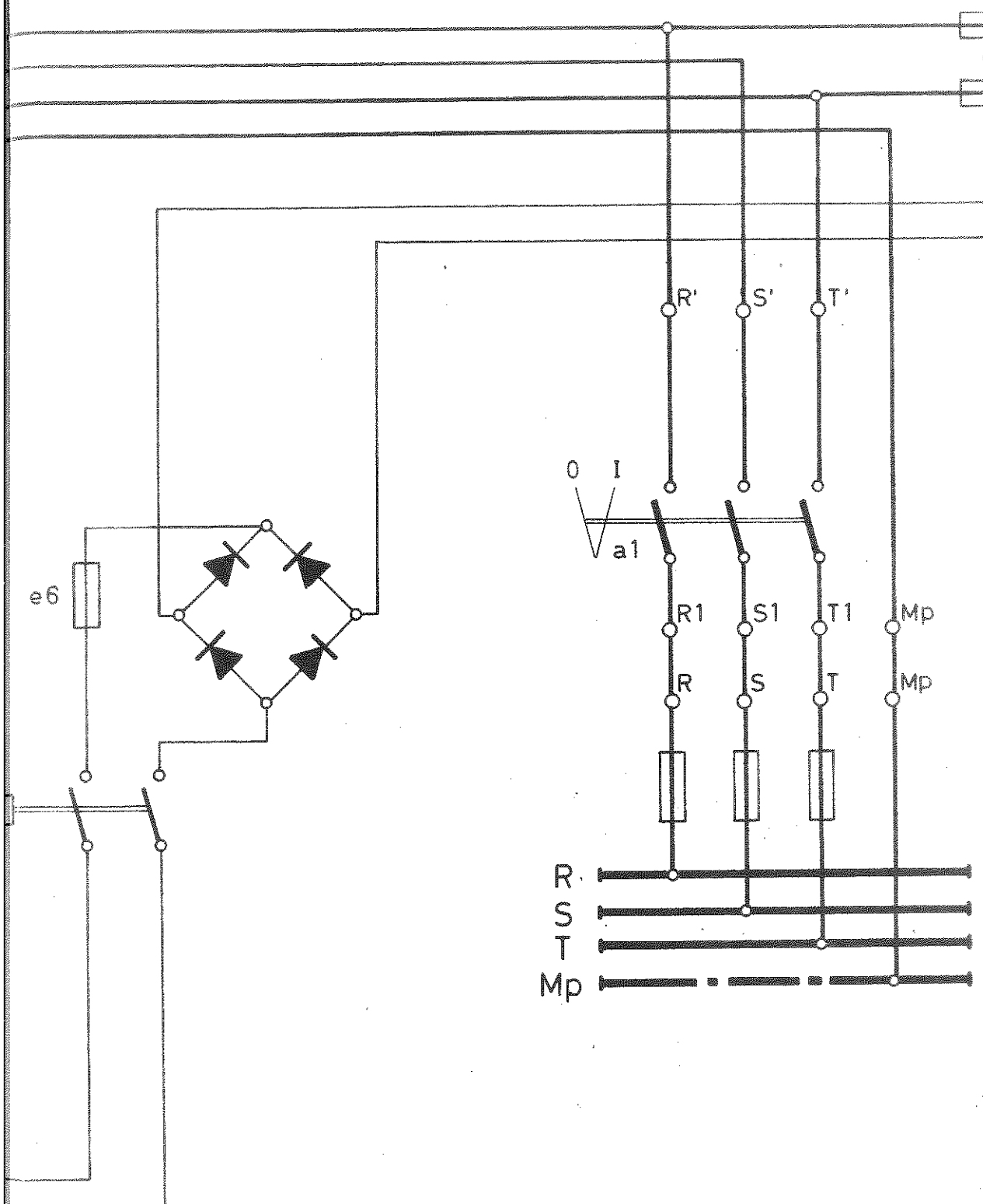

Netz 380 oder 220 V
50 Hz
Réseau 380 ou 220 V
50 périodes
380 or 220 volts
50 c/s.

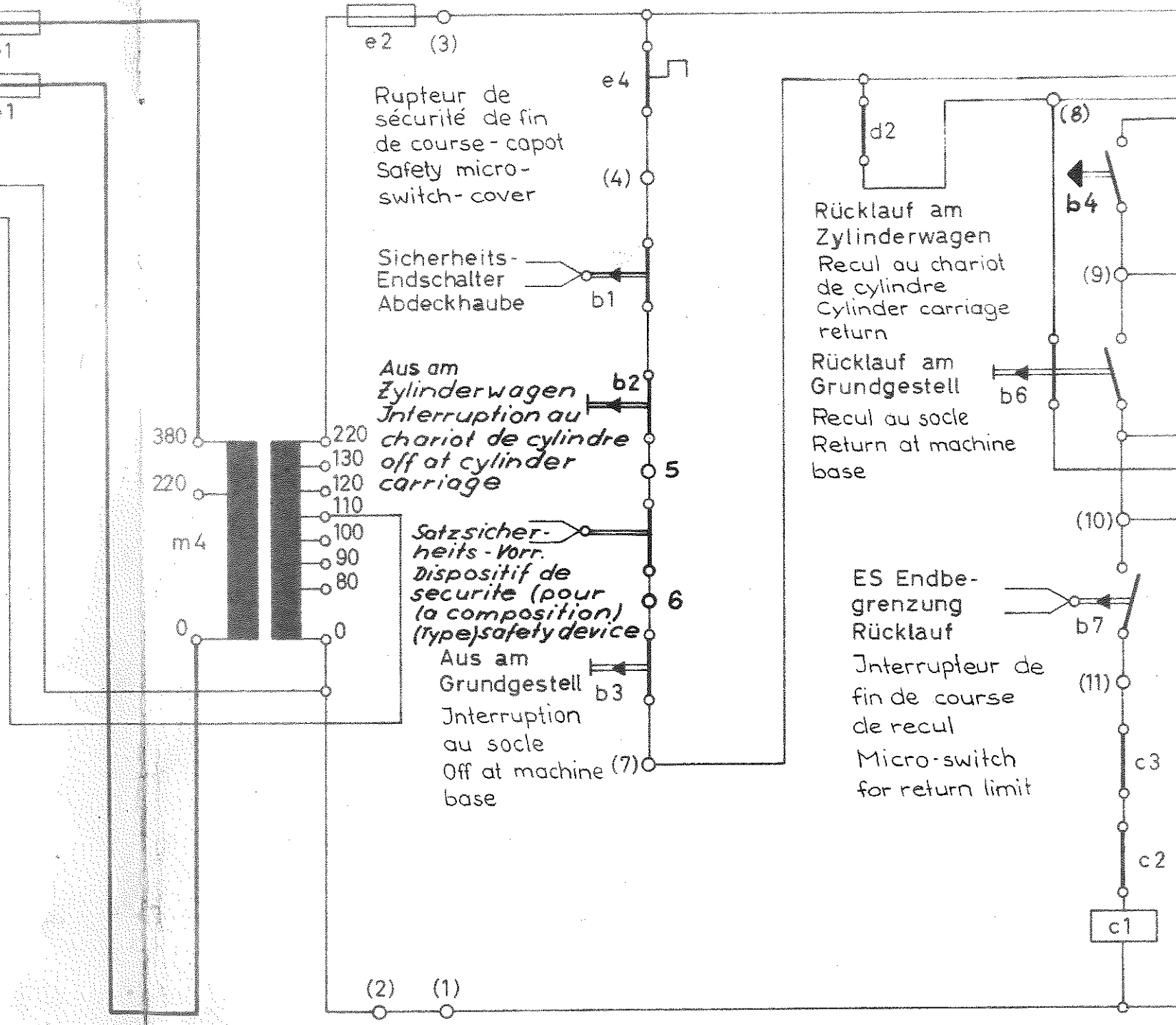

S	Ö
12	18
27	33

Motorschül
Rücklauf
Disjoncte
Remote co

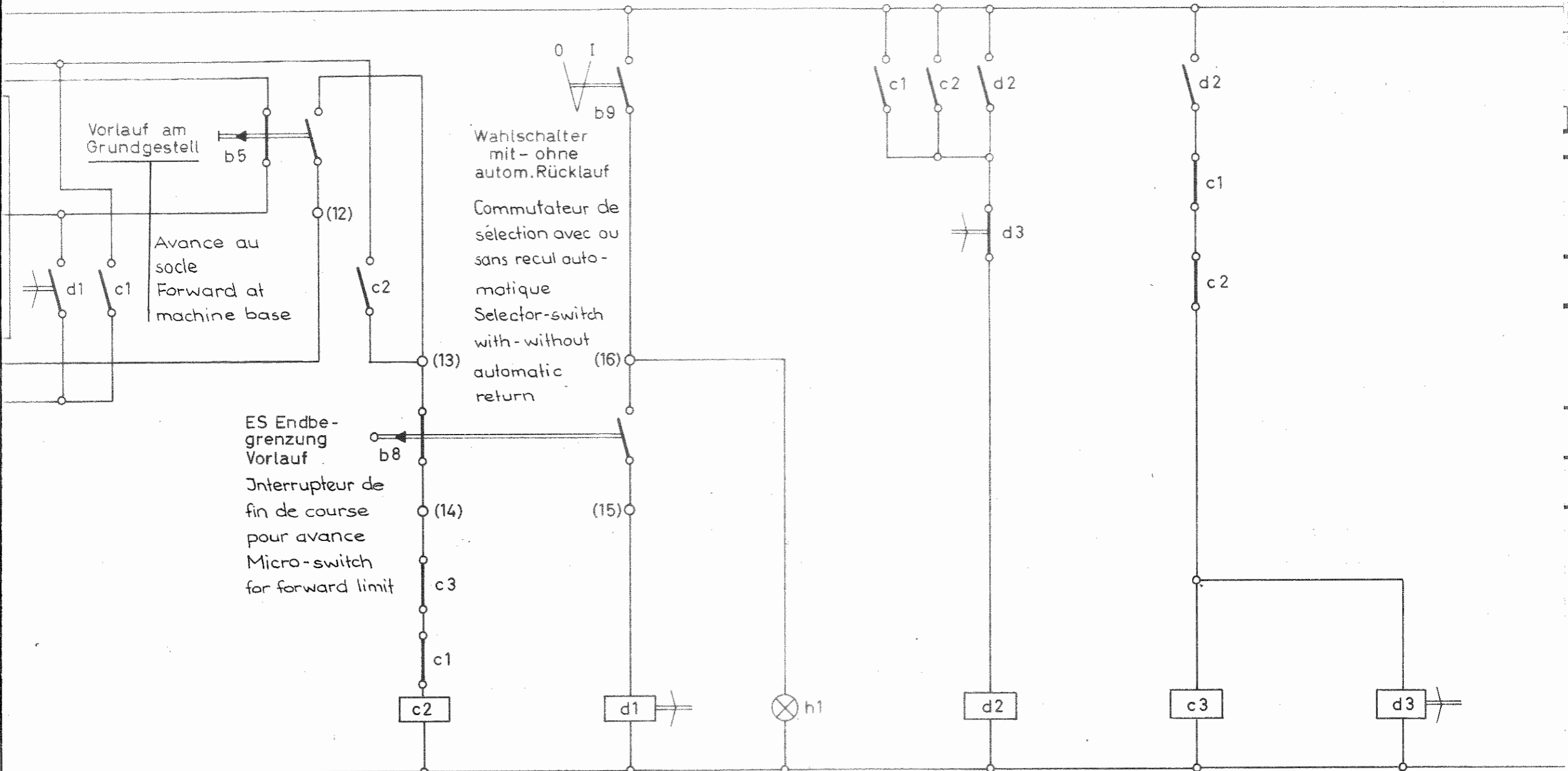

S Ö 17 9 28 33	S Ö 11		S Ö 29 5 33	S Ö 9 18	S Ö 29
----------------------------	-------------	--	-----------------------	------------------	-------------

Motorschütz
ZR
SL
HS
Bremsschütz
ZR

<p>Vorlauf Disjoncteur du moteur-avance Remote control switch to motor - forward</p>	<p>Rücklauf recul return</p>
<p>Bremseinrichtung Disjoncteur de frein - Equipement de frein Remote control brake switch - Braking equipment</p>	

ur du moteur - Recul
ontrol switch to motor - return

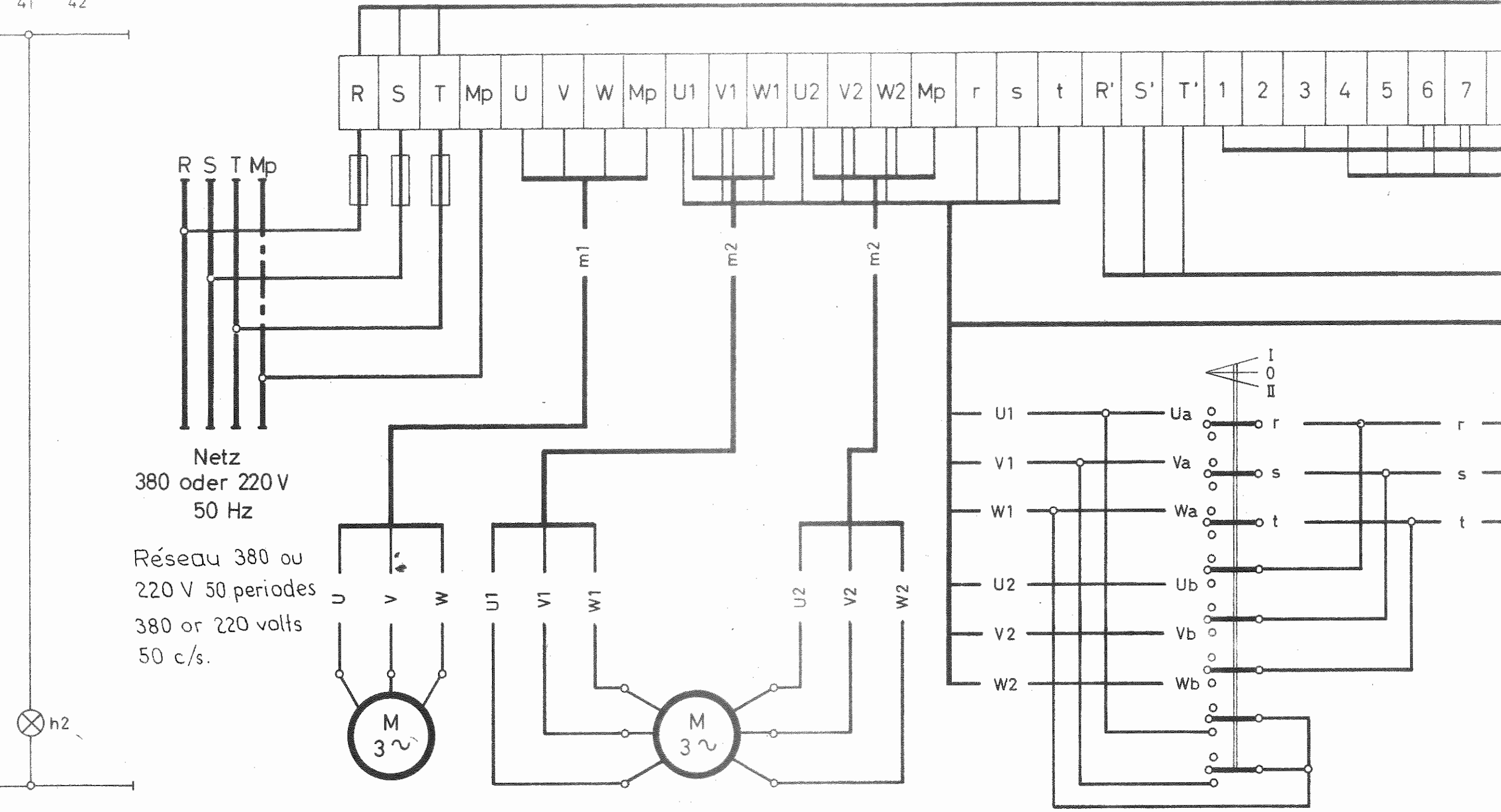

Netz
380 oder 220 V
50 Hz

Réseau 380 ou
220 V 50 périodes
380 or 220 volts
50 c/s.

Anlage
ein
Interrupteur principal mis en circuit.
Main switch (Automatic carriage) on

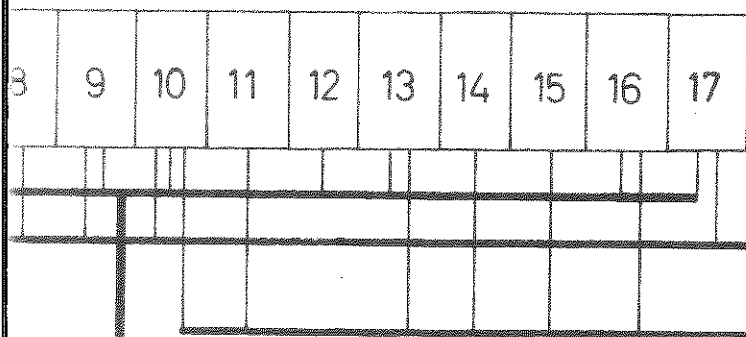

Interrupteur principal - Hauptschalter - Main switch

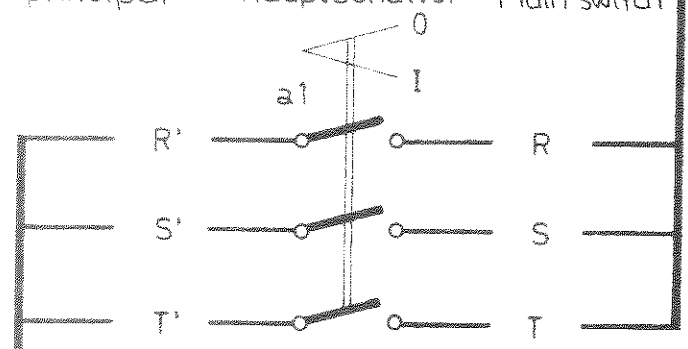

Interrupteur de fin de course de recul Endbegrenzung Rücklauf Micro return

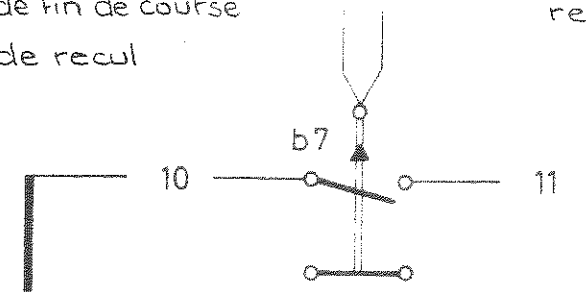

Interrupteur de fin de course pour avance Micro-switch for forward limit

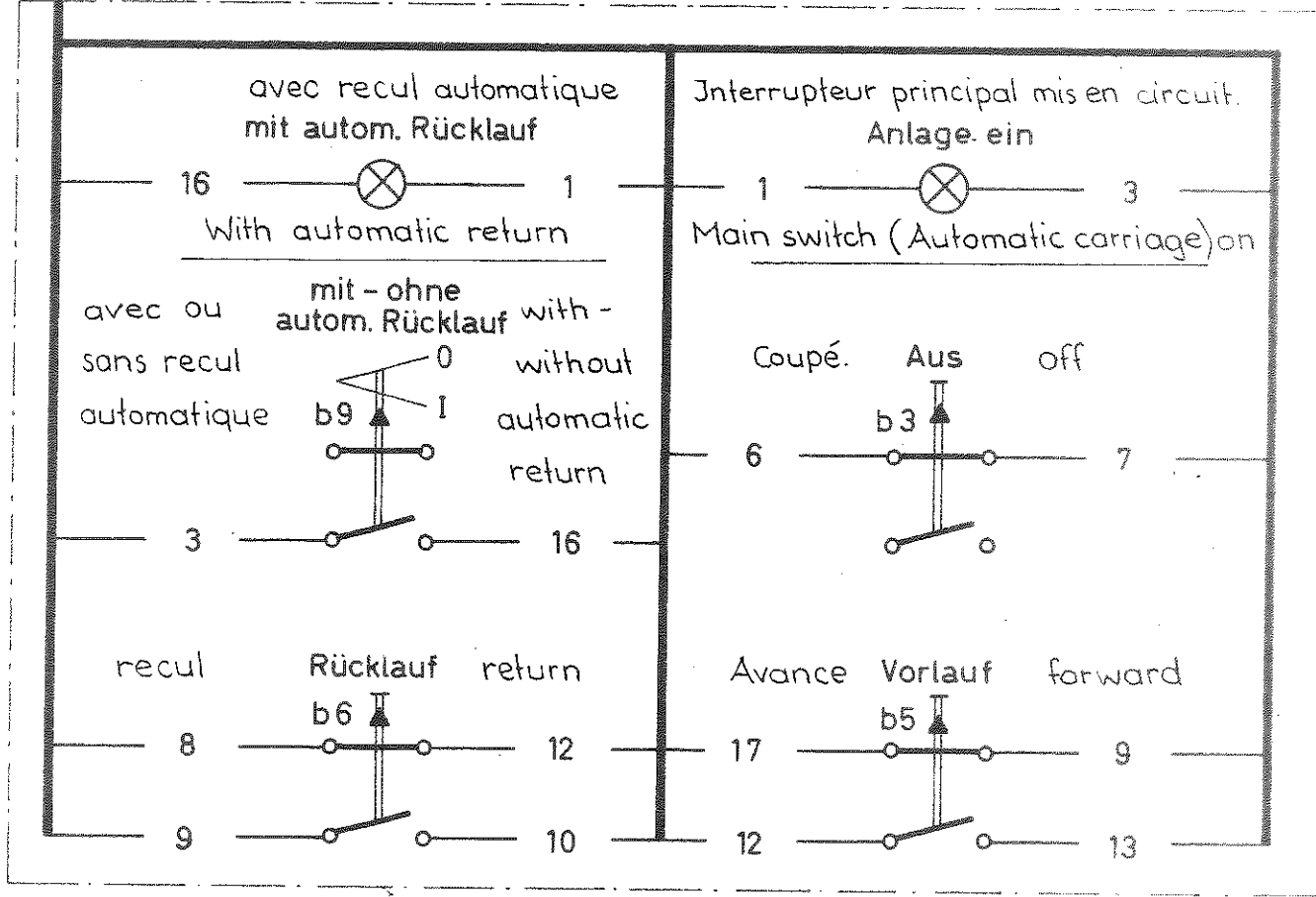
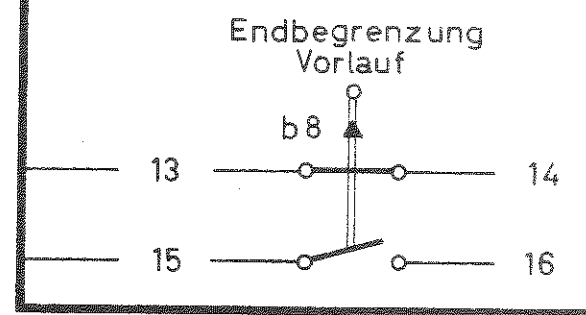

Rupteur de sécurité de fin de course - Sicherheits-Endschalter - safety-micro-switch - cover capot

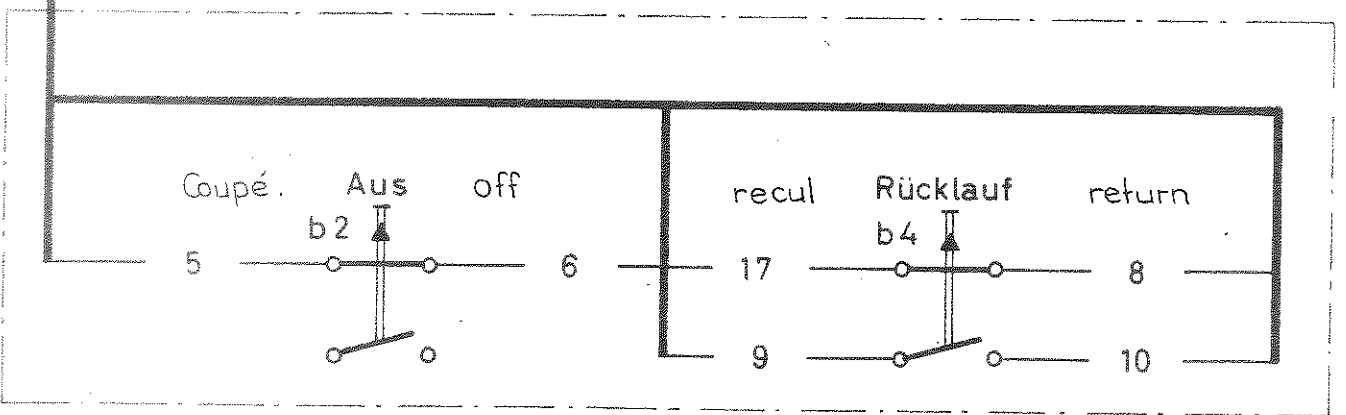
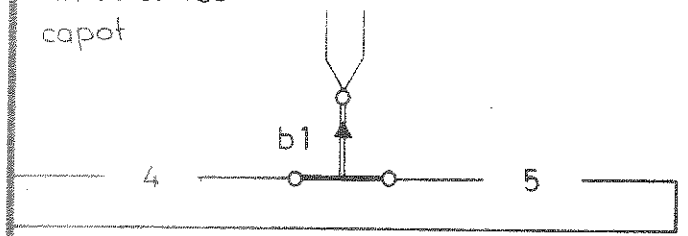

-switch for
limit

Haas u. Kellhofer Singen / Hohentwiel			H. Weiner, Hockenheim		
	Datum	Name	 ANTRIEBS- UND REGELTECHNIK GmbH		
Gez.	14.4.1965	<i>Krauer</i>			
Gepr.	14.4.1965	<i>HB</i>			
Ges.					
Übersichts - Stromlauf - und Anschlußplan der Andruckmaschine GX2 u. GX3			12a.4u.1735		